

Wilo-Yonos PARA



The Wilo-Yonos PARA is the latest high-efficiency pump series which is specially designed in order to fulfill the special demands of the OEM industry. The Wilo-Yonos PARA sets the standard for energy-saving solutions required for integrated hydraulic systems. Equipped with a self controlled Red button or externally PWM control, the Wilo-Yonos PARA is the perfect choice for a one-to-one replacement of most existing electronic pumps. This series is available in various cast iron and composite pump housings and is thus highly versatile. At the leading edge of technology, the Wilo-Yonos PARA provides best-in-class performances: it has a three times higher starting torque than most comparable heating pumps and fulfils highest mechanical, electrical and hydraulic requirements.

Special features/product benefits

- "Best in class" High Efficiency pump of the market due to ECM technology
- Up to 80% electricity savings compared to previous uncontrolled range of heating pumps
- Self controlled pump (Red button) or externally controlled (PWM signal)
- Unique LED user interface gives information about the pump functioning
- High starting torque for reliable start-up
- Hot water heating systems of all kinds, in the temperature range of 0 °C to +95 °C (110 °C for ST version)
- Designed for easy integration due to compact design
- Inrush current peak less than 3A
- Self protecting modes of electronic motor
- Preventing flow noises
- Stand-by consumption less than 1 W
- Functions adapted specially to the demands of the OEM market
- Standard delivery with power cable and signal cable
- Cathodically coated (KTL) cast iron pump housing to prevent corrosion when condensation occurs, or OEM composite pump housing

Heating application

In nearly all circulation systems, correctly sized controlled glandless pumps ensure adequate heat supply at all times at significantly reduced energy costs, while at the same time preventing noise generation.

Electronic performance control

Self controlled model with Red button (Type RKA/RKC)

Available control modes

Control mode Δp -c:

In the Δp -c control mode, the electronic module keeps the differential pressure generated by the pump constant at the set differential pressure setpoint H_S over the permissible volume flow range.

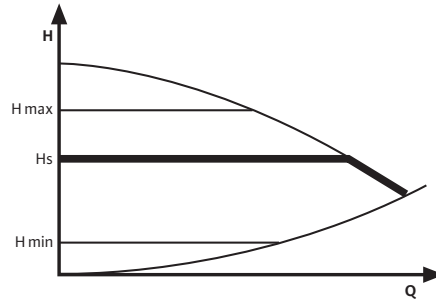

Control mode Δp -v:

In the Δp -v control mode, the electronic module changes the differential pressure setpoint to be maintained by the pump in linear fashion between H_S and $\frac{1}{2} H_S$. The differential pressure setpoint value H varies with the volume flow Q .

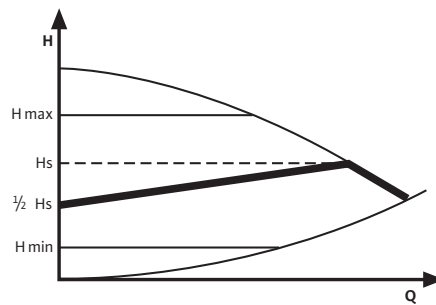

Venting routine

The integrated venting routine supports a bleeding of the overall heating system. After a manual setting, the routine runs for 10 minutes alternating at low and high speed of the pump. At the end of the process, the pump switches automatically to a pre-set speed. After that, the desired control mode can be set at the red button.

Constant speed I, II, III

In this operating mode the pump is not self regulating its speed. The pump is operating constantly with a fixed speed in pre-set position.

Manual control panel

Control button

The control mode and the differential pressure setpoint at Δp -c for constant differential pressure, Δp -v for variable differential pressure and pre-setting the constant speed can be set easily and safely, directly at the pump. Depending on customer wishes, a pre-setting of the control mode/setpoint can be done at the factory.

Wilo-Yonos PARA

RKA type



RKA

- Local setting of the constant differential pressure set-point at $\Delta p-c$ on the right side
- Local setting of the variable differential pressure set-point at $\Delta p-v$ on the left side
- Medium position for activating the venting function

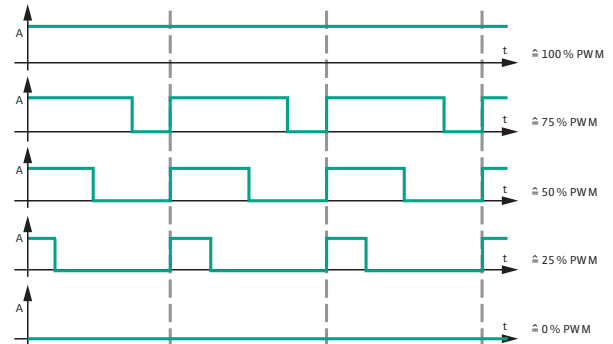

RKC type



RKC

- Local setting of the variable differential pressure set-point at $\Delta p-v$ on the left side
- A fixed constant speed is set on the right side. In this operating mode the pump is not self regulating its speed.
- Medium position for minimum speed

PWM signal logic 1 (heating):

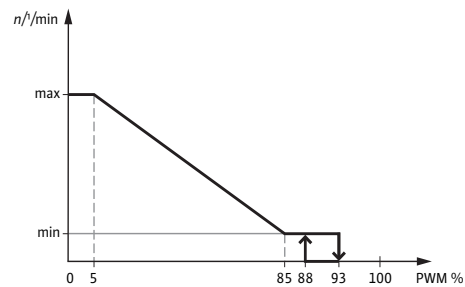

PWM input signal [%]

- < 5 Pump runs at maximum speed
- 5–85 Pump speed decreases linearly from maximum to minimum
- 85–93 Pump runs at minimum speed (operation)
- 85–88 Pump runs at minimum speed (start-up)
- 93–100 Pump stops (Standby)

External control via a PWM signal

The actual/setpoint level assessment required for control is referred to a remote controller. The remote controller sends a PWM signal as an actuating variable to the Wilo-Yonos PARA. The PWM signal generator gives a periodic order of pulses to the pump (the duty cycle), according to DIN IEC 60469-1. The actuating variable is determined by the ratio between pulse duration and the pulse period. The duty cycle is defined as a ratio without dimension, with a value of 0 ... 1 or 0 ... 100 %. This is explained in the following with ideal pulses which form a rectangular wave.

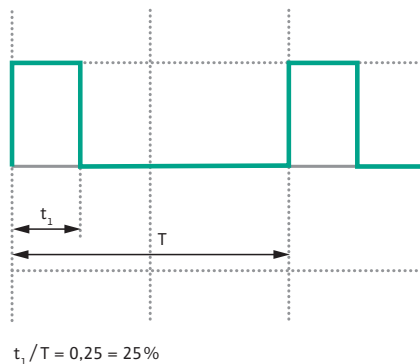

PWM signal logic 2 (solar):

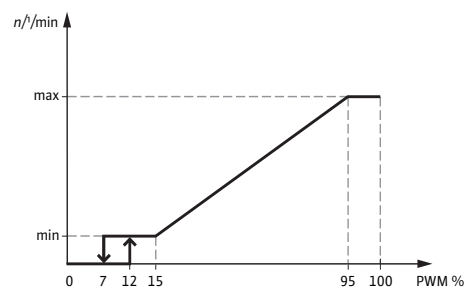

PWM input signal [%]

- < 7 Pump stops (Standby)
- 7–15 Pump runs at minimum speed (operation)
- 12–15 Pump runs at minimum speed (start-up)
- 15–95 Pump speed increases linearly from minimum to maximum
- > 95 Pump runs at maximum speed

Signal frequency: 100 Hz–5000 Hz (1000 Hz nominal)
 Signal amplitude: Minimum 3.6 V at 3 mA
 up to 24 V for 7.5 mA absorbed by the pump interface
 Signal polarity: none

Planning guide

Wilo-Yonos PARA

Electrical connection

To ensure a safe and easy electrical connection, the Wilo-Yonos PARA pumps are equipped with an integrated Molex 3-way connector or an overmoulded connector and depending on the available functions, with a control cable.

Mains connection

For mains power supply 1~230 V/50 Hz

Yonos PARA: with integrated Molex 3-way connector

PWM version



Red Knob version



Yonos PARA: with overmoulded connector

Disconnection of mains cable from terminal box not possible. PWM connector can be disconnected

PWM version



Red Knob version



Cables

Standard cables

Overmoulded cable with brass end splices

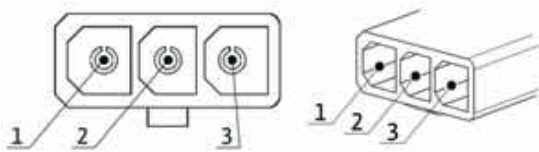

- 1) L1, 1~230 V/50 Hz
- 2) Neutral N
- 3) Earth conductor

The mating plug to the OEM-plug can be ordered with one of the following suppliers. (Wilo does not assume any liability for the products supplied by these manufacturers):

- LTE (www.lte.it)
- FACON (www.facon.it)

Available mains cables

Standard	1 m, 3-core cable with end splices
Optional	0.5 m, 3-core cable with end splices 1.5 m, 3-core cable with end splices 2.0 m, 3-core cable with end splices according to customer specifications

- black/brown: L1, 1~230V/50Hz
- blue: Neutral N
- yellow/green: Earth conductor

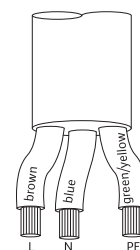

Wilo-Yonos PARA

Optional: short cables with specific connector

Volex cable, IEC 60320-C6 (cable length ca. 300 mm)



3 way / Molex cable (cable length ca. 200 mm)



WS8 cable + WS8 connector (cable length ca. 200 mm)



Optional: Wilo Connector

No tools are required to connect the mains cable to the Wilo-Connector:

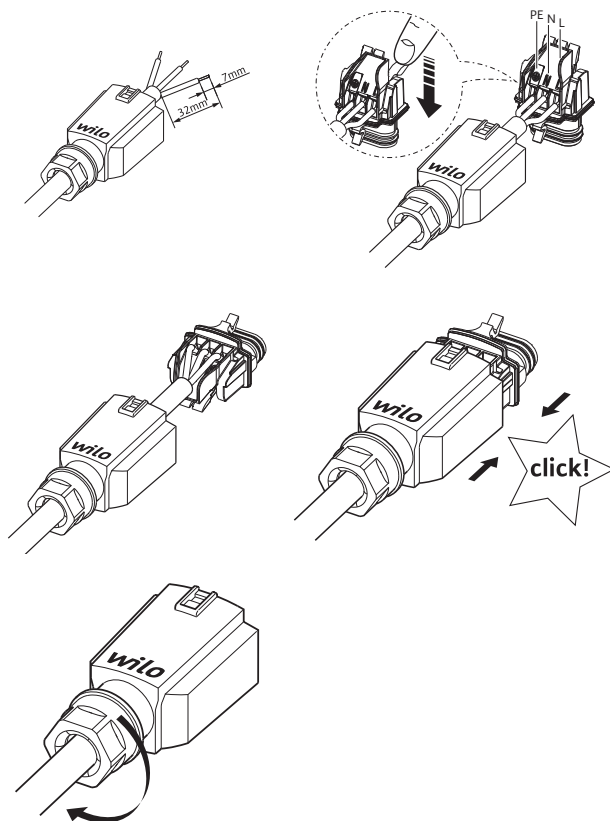

PWM Control cables

2-core cable

For connecting the analogue PWM interface
PWM signal cables supplied without a connector have dual polarity.

Core + (brown)
Core - (blue)



Available control cables

Standard	1 m, 2-core cable with end splices
Optional	0.5 m, 2-core cable with end splices 1.5 m, 2-core cable with end splices 2.0 m, 2-core cable with end splices according to customer specifications

Permissible temperature range

The Wilo-Yonos PARA range is equipped with a self protecting mode: In the event of too high temperature, outside the permissible temperature range, the electronics reduces automatically the power consumption until normal operating conditions return.

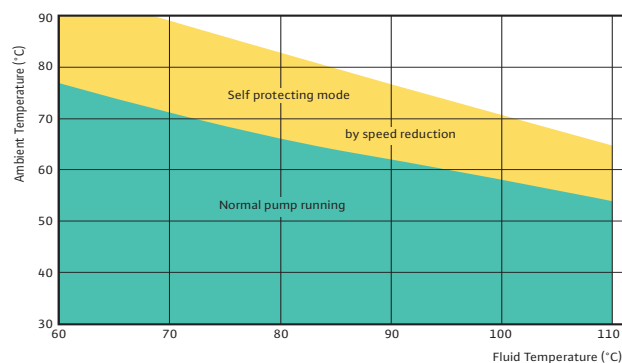

Example: at a fluid temperature of 90 °C and at an ambient temperature of 59 °C, the delivery head can decrease by 0.5 m depending on the pressure losses of the system.

Planning guide

Wilo-Yonos PARA

Designation, name plate of the Wilo-Yonos PARA series

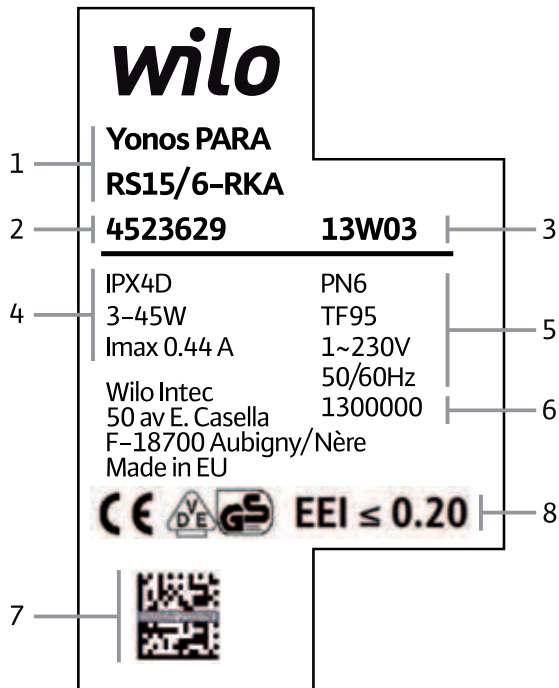

- 1 Pump type
- 2 Article number
- 3 Production date (year/week)
- 4 Protection class IP/Power consumption/Electricity
- 5 Operating pressure/max. Fluidtemperature/Voltage/Frequency
- 6 Wilo Label number
- 7 Code and serial number
- 8 Energy efficiency index (EEI)
The benchmark of the most efficient circulator is EEI ≤ 0.20, part 3

Permitted installation positions

Wilo-Yonos PARA

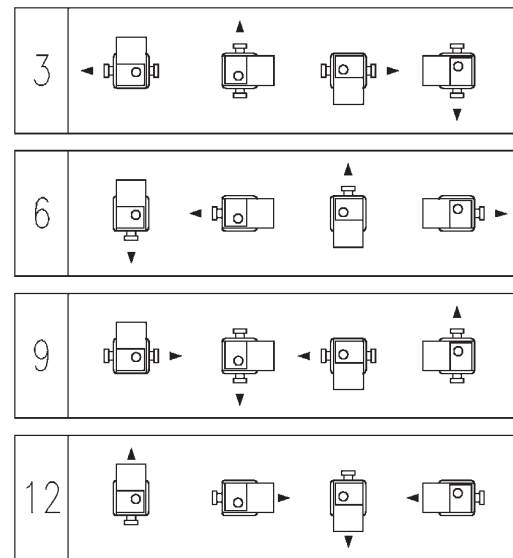

3, 6, 9 and 12 o'clock are the electronic module positions for the indicated direction of flow at the pump housing.

Series overview

Hydraulic operational overview

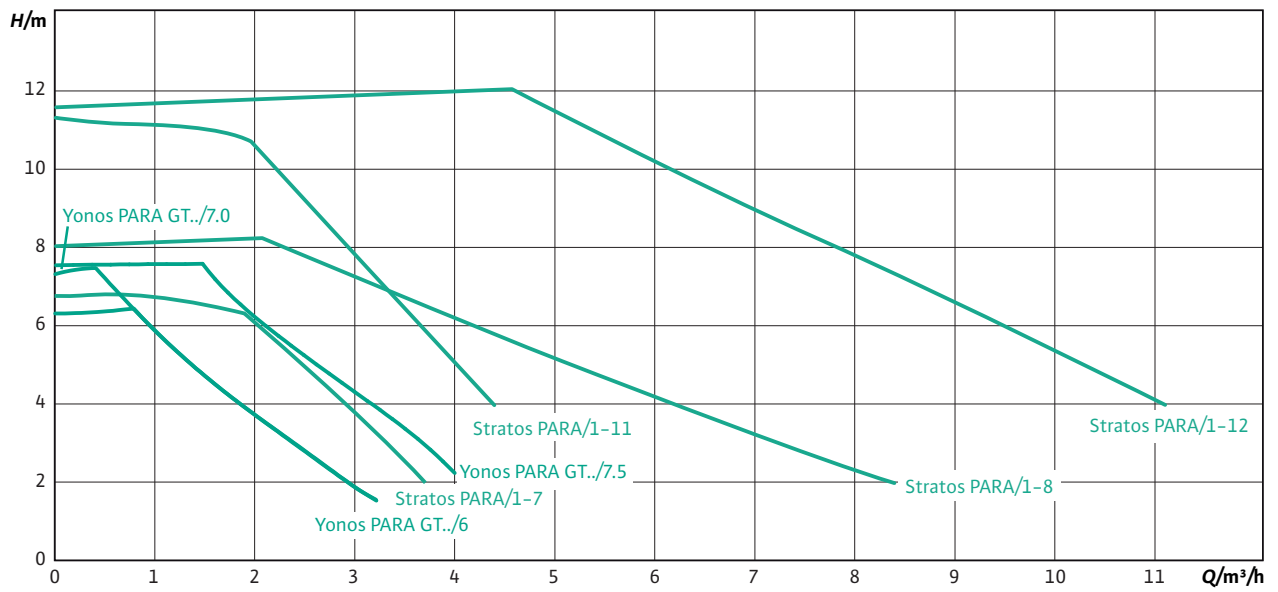

Geothermal energy systems

High-efficiency pumps

Equipment/function	Wilo-Yonos PARA GT...		
	15/6 RKC 25/6 RKC 30/6 RKC	15/7.5 RKC 25/7.5 RKC 30/7.5 RKC	15/7.0 (7.5) PWM1 25/7.0 (7.5) PWM1 30/7.0 (7.5) PWM1
Operating modes			
Manual control mode (n=constant)	• (RKC)	• (RKC)	• via PWM
Δp -c for constant differential pressure	• ($H_{\min.} = 1 \text{ m}$, $H_{\max.} = 6 \text{ m}$)	• ($H_{\min.} = 1 \text{ m}$, $H_{\max.} = 7.5 \text{ m}$)	–
Δp -v for variable differential pressure	–	–	–
Manual functions			
Operating mode setting	•	•	–
Differential-pressure setpoint setting	•	•	•
Automatic functions			
Infinitely variable power adjustment depending on the operating mode	•	•	•
Deblocking function	•	•	•
Soft start	•	•	•
Full motor protection with integrated trip electronics	–	–	–
Venting routine	–	–	–
External control functions			
Control input "Analogue In 0 ... 10 V" with cable break function (remote speed adjustment)	–	–	–
Control input "Analogue In 0 ... 10 V" without cable break function (remote setpoint adjustment)	–	–	–
Control input PWM	–	–	•
Signal and display functions			
Collective fault signal (potential-free NC contact)	–	–	–
Equipment/scope of delivery			
Red button	•	•	–
Version without red button (=external control)	–	–	•
Wrench attachment point on pump body	•	•	•
Including power cable	on request	•	•
Including power plug	on request	on request	on request
Including control cable	–	–	on request
Including seals for threaded connection	on request	on request	on request
Including installation and operating instructions	on request	on request	on request
Including thermal insulation	on request	on request	on request
Incl. Cooling-Shell for cooling	–	–	–
Individual packaging	on request	on request	on request
Collective packaging	•	•	•

Geothermal energy systems

High-efficiency pumps

Series description Wilo-Yonos PARA GT .../6 Red Knob, .../7.0 PWM1



Design

Glandless circulation pump with a cast iron pump housing and threaded. EC-motor with automatic power adjustment and self-protecting modes. Operation by Red Knob technology or remote control via external PWM signal. Equipped with LED user interface. Mechanical design dedicated for geothermal applications.

Application

Circulation in geothermal systems in the medium temperature range of -20 °C to +95 °C.

Type key

Example:	Yonos PARA GT 15/6 RKC FS 130 12
Yonos	Electronically controlled high-efficiency pump
PARA	pump range adapted to requirements of the OEM market
GT	Pump dedicated for solar thermal applications Standard cast iron pump housing
15/	Nominal diameter: 15 threading 1" 25 threading 1 1/2" 30 threading 2"
6	Nominal delivery head range [m]
RKC	The pump is controlled by Red Knob technology: RKC = Δp -v / constant speed I, II, III or PWM1 = the pump is controlled by an external system via PWM1 signal
FS	Overmoulded cable with brass end splices Optional: connector
130	Pump housing length: 110 mm, 130 mm or 180 mm
12	Electronic box orientation

Technical data		
	.../6	.../7
Approved fluids (other fluids on request)		
Heating water (in accordance with VDI 2035)	•	
Water-glycol mixtures (max. 1:1; above 20% admixture, the pumping data must be checked)	•	
Power		
Energy efficiency index (EEI)	≤ 0.20	
Max. delivery head	6.3 m	7.3 m
Max. volume flow	3.3 m ³ /h	
Permitted field of application		
Temperature range at max. ambient temperature	of 58°C = 0 to 100°C of 62°C = 0 to 90°C of 66°C = 0 to 80°C of 71°C = 0 to 70°C	
Maximum static pressure	6 bar	
Electrical connection		
Mains connection	1~230 V, 50/60 Hz	
Motor/electronics		
Electromagnetic compatibility	EN 61800-3	
Emitted interference	EN 61000-6-3 EN 61000-6-4	
Interference resistance	EN 61000-6-2 EN 61000-6-1	
Speed control	Frequency converter	
Protection class	IP X4D	
Insulation class	F	
Minimum suction head at suction port for avoiding cavitation at water pumping temperature		
Minimum suction head at 50 / 95 / 110 °C	0.5 / 4.5 / 0 m	

• = available, - = not available

Pump curves Wilo-Yonos PARA GT .../6 Red Knob, .../7.0 PWM1

Wilo-Yonos PARA GT 15/6, 25/6, 30/6

$\Delta p-v$ (variable)

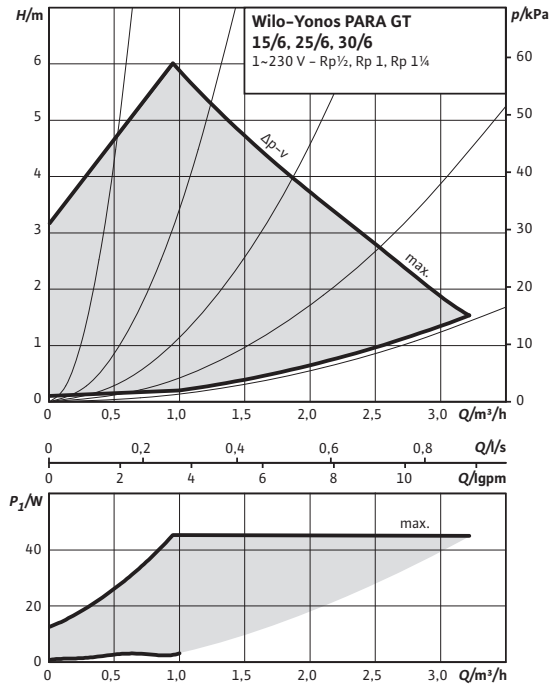

Wilo-Yonos PARA GT 15/6, 25/6, 30/6

Constant speed I, II, III

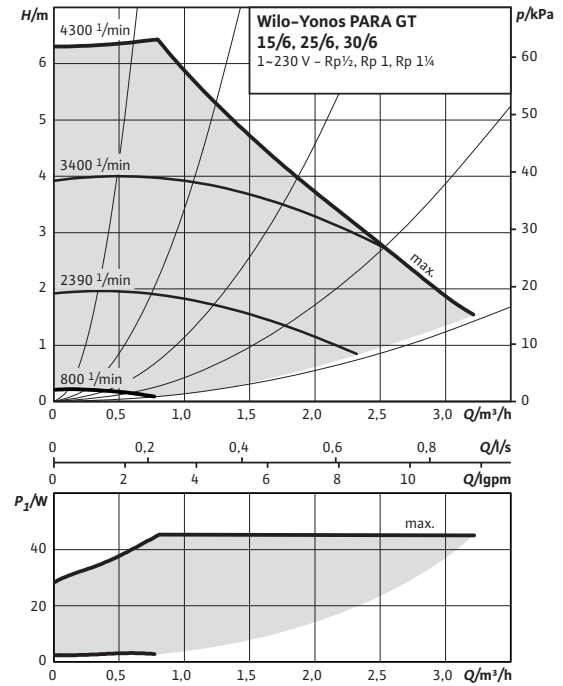

Wilo-Yonos PARA GT 15/7.0, 25/7.0, 30/7.0

External control via PWM 1

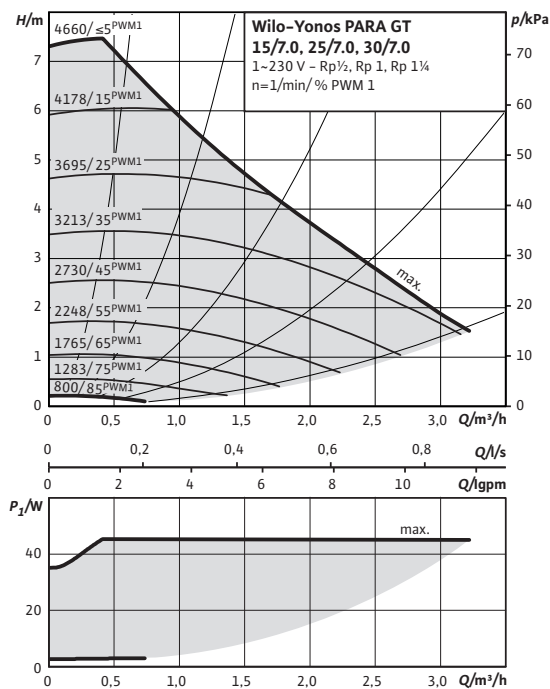

Geothermal energy systems

High-efficiency pumps

Dimensions, motor data Wilo-Yonos PARA GT .../6 Red Knob, .../7.0 PWM1

Motor data

Wilo-Yonos PARA GT...	Speed	Power consumption 1~230 V	Current at 1~230V	Motor protection
	n	P_1	I	–
	rpm	W	A	–
.../6 RKC	800 - 4300	3-45	0.03 - 0.44	integrated
.../7.0 PWM1	800 - 4660	3-45	0.03 - 0.44	integrated

Materials

Wilo-Yonos PARA GT...	Pump housing	Impeller	Pump shaft	Bearing
.../6 RKC	Cast iron with cataphoresis treatment	PP composite with GF 40%	Stainless steel	Carbon, metal impregnated
.../7.0 PWM1				

Dimension drawing

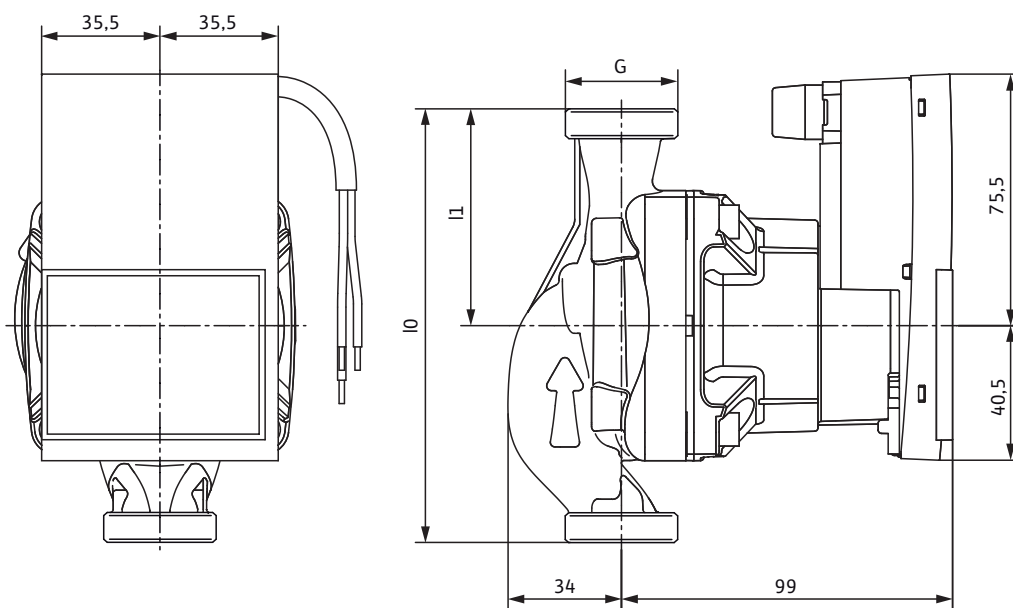

Dimensions, weights

Wilo-Yonos PARA GT...	Threaded pipe union	Thread	Overall length	Dimensions	Weight approx.
	–		l_0	$L1$	m
	–			mm	kg
GT 15/6 RKC	Rp ½	G 1	130	65	1.7
GT 25/6 RKC	Rp 1	G 1½	130	65	1.8
GT 25/6 RKC	Rp 1	G 1½	180	90	1.9
GT 30/6 RKC	Rp 1¼	G 2	180	90	2.1
GT 15/7.0 PWM	Rp ½	G 1	130	65	1.7
GT 25/7.0 PWM	Rp 1	G 1½	130	65	1.8
GT 25/7.0 PWM	Rp 1	G 1½	180	90	1.9
GT 30/7.0 PWM	Rp 1¼	G 2	180	90	2.1

Series description Wilo-Yonos PARA GT .../7.5 Red Knob, PWM1



Design

Glandless circulation pump with a cast iron pump housing and threaded. EC-motor with automatic power adjustment and self-protecting modes. Operation by Red Knob technology or remote control via external PWM signal. Equipped with LED user interface. Mechanical design dedicated for geothermal applications.

Application

Circulation in geothermal systems in the medium temperature range of -20 °C to +95 °C.

Type key

Example:	Yonos PARA GT 15/7.5 RKC FS 130 12
Yonos	Electronically controlled high-efficiency pump
PARA	pump range adapted to requirements of the OEM market
GT	Pump dedicated for solar thermal applications Standard cast iron pump housing
15/	Nominal diameter: 15 threading 1" 25 threading 1 1/2" 30 threading 2"
7.5	Nominal delivery head range [m]
RKC	The pump is controlled by Red Knob technology: RKC = $\Delta p-v$ / constant speed I, II, III or PWM1 = the pump is controlled by an external system via PWM signal
FS	Overmoulded cable with brass end splices Optional: connector
130	Pump housing length: 110 mm, 130 mm or 180 mm
12	Electronic box orientation

Technical data

Approved fluids (other fluids on request)	
Heating water (in accordance with VDI 2035)	•
Water-glycol mixtures (max. 1:1; above 20% admixture, the pumping data must be checked)	•
Power	
Energy efficiency index (EEI)	≤ 0.21
Max. delivery head	7.6 m
Max. volume flow	4 m ³ /h
Permitted field of application	
Temperature range at max. ambient temperature	of 58°C = 0 to 100°C of 62°C = 0 to 90°C of 66°C = 0 to 80°C of 71°C = 0 to 70°C
Maximum static pressure	6 bar
Electrical connection	
Mains connection	1~230 V, 50/60 Hz
Motor/electronics	
Electromagnetic compatibility	EN 61800-3
Emitted interference	EN 61000-6-3 EN 61000-6-4
Interference resistance	EN 61000-6-2 EN 61000-6-1
Speed control	Frequency converter
Protection class	IP X4D
Insulation class	F
Minimum suction head at suction port for avoiding cavitation at water pumping temperature	
Minimum suction head at 50 / 95 °C	0.5 / 4.5 m

• = available, - = not available

Geothermal energy systems

High-efficiency pumps

Pump curves Wilo-Yonos PARA GT .../7.5 Red Knob, PWM1

Wilo-Yonos PARA GT 15/7.5, 25/7.5, 30/7.5

$\Delta p-v$ (variable)

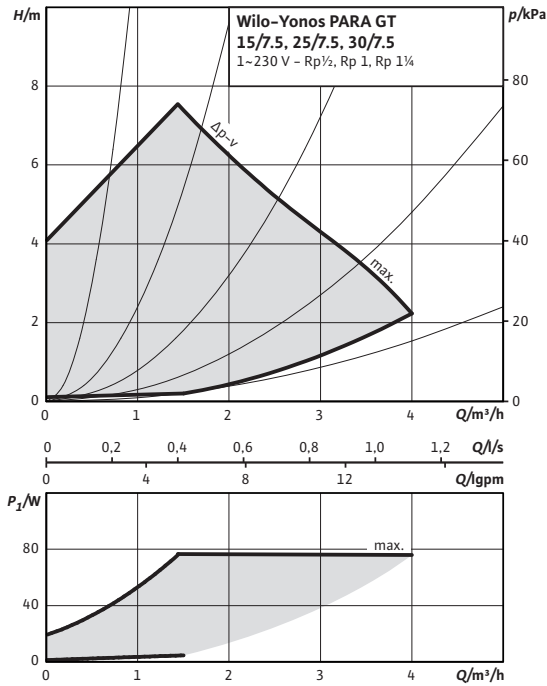

Wilo-Yonos PARA GT 15/7.5, 25/7.5, 30/7.5

Constant speed I, II, III

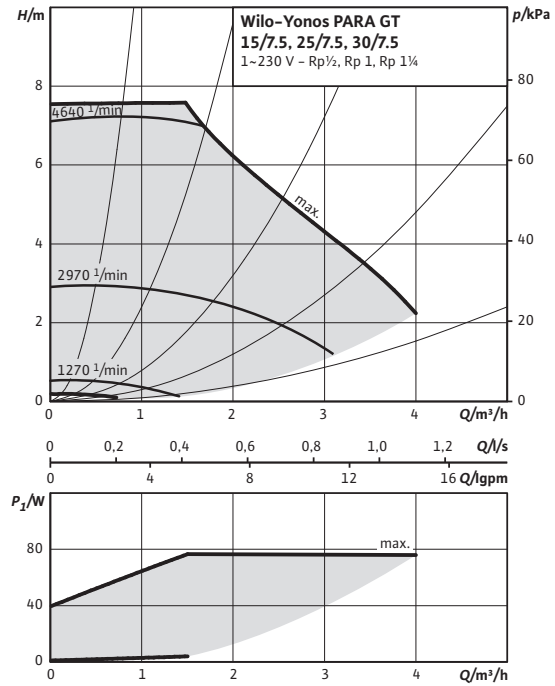

Wilo-Yonos PARA GT 15/7.5, 25/7.5, 30/7.5

External control via PWM 1

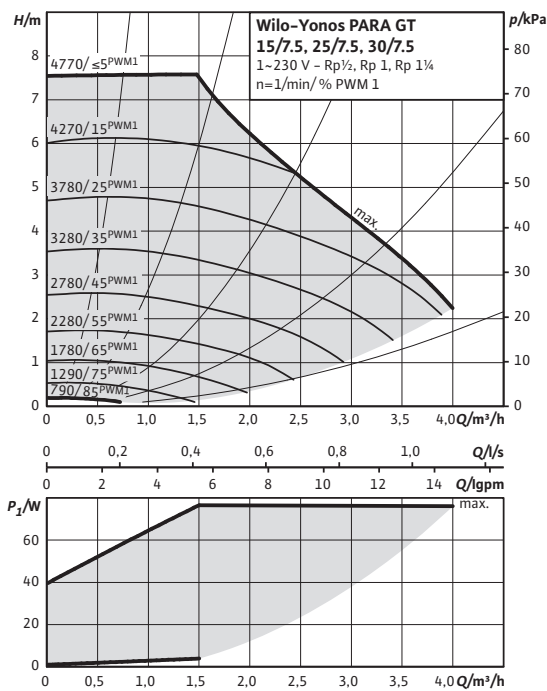

Dimensions, motor data Wilo-Yonos PARA GT .../7.5 Red Knob, PWM1

Motor data

Wilo-Yonos PARA GT...	Speed	Power consumption 1~230 V	Current at 1~230V	Motor protection
	n	P_1	I	–
	rpm	W	A	–
.../7.5 RKC/PWM1	800 - 4770	3-76	0.03 - 0.70	integrated

Materials

Wilo-Yonos PARA GT...	Pump housing	Impeller	Pump shaft	Bearing
.../7.5 RKC/PWM1	Cast iron with cataphoresis treatment	PP composite with GF 40%	Stainless steel	Carbon, metal impregnated

Dimension drawing

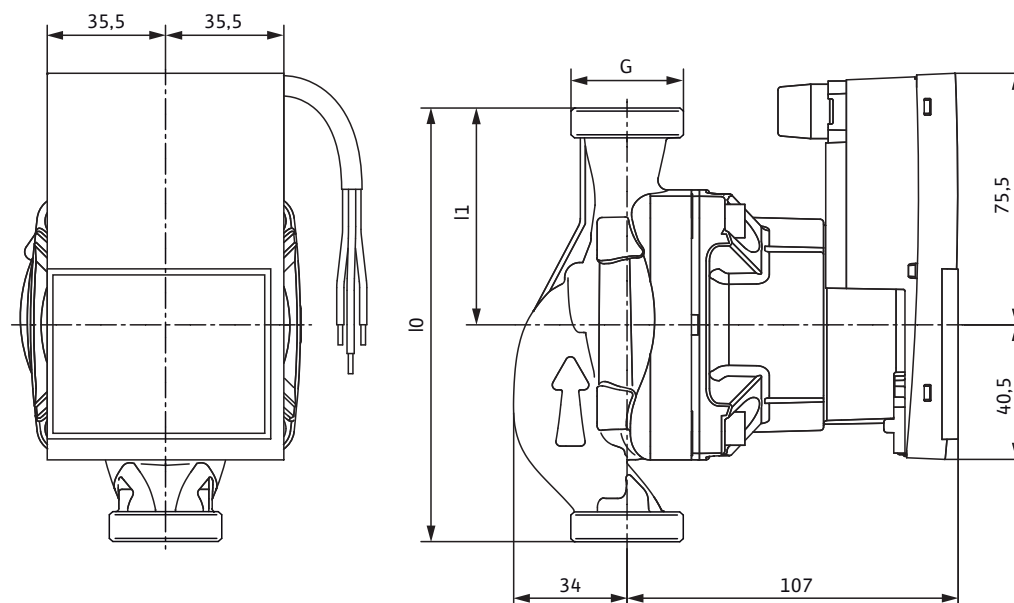

Dimensions, weights

Wilo-Yonos PARA GT...	Threaded pipe union	Thread	Overall length	Dimensions	Weight approx.
	–		l_0	$L1$	m
	–			mm	kg
GT 15/7.5 RKC/PWM1	Rp ½	G 1	130	65	1.8
GT 25/7.5 RKC/PWM1	Rp 1	G 1¼	130	65	1.9
GT 25/7.5 RKC/PWM1	Rp 1	G 1½	180	90	2.1
GT 30/7.5 RKC/PWM1	Rp 1¼	G 2	180	90	2.2

Wilco-Cooling-Shell, Wilo thermal insulation shells

Wilo thermal insulation shells



> User benefits

- Reduces the heat losses of the pump by up to 85 % (depending on the electrical power P_1)
- Reduces the overall energy consumption of the heating system
- Saves energy costs
- Resistant to moisture, salts, many acids, most greases and solvents
- Ensures even temperature distribution at the pump
- Protects the pump from outside moisture
- Groundwater-neutral, propellant-free, formaldehyde-free
- 100 % recyclable
- Fire resistance classification B2

> Suitable for pumps of the series:

- Yonos PARA .../6; 130 mm, 180 mm
- Yonos PARA .../7.0; 130 mm, 180 mm
- Yonos PARA .../7.5; 130 mm, 180 mm
- Stratos PARA /1-7; 130 mm, 180 mm
- Stratos PARA /1-11; 180 mm
- Stratos PARA /1-8; 180 mm
- Stratos PARA /1-12; 180 mm
- Stratos PARA Z/1-11; 180 mm
- Stratos PARA Z/1-8; 180 mm
- Stratos PARA Z/1-12; 180 mm

Wilo-Cooling-Shell



> Wilo-Cooling-Shell

Diffusion-proof insulation of pump housings in cold water applications.

Suitable for pumps of the series:

- Yonos PARA .../6; 130mm, 180 mm
- Yonos PARA .../7.0; 130mm, 180 mm
- Yonos PARA .../7.5; 130mm, 180 mm
- Stratos PARA /1-7; 180 mm
- Stratos PARA /1-8; 180 mm
- Stratos PARA /1-11; 180 mm
- Stratos PARA /1-12; 180 mm
- Stratos PARA Z/1-11; 180 mm
- Stratos PARA Z/1-8; 180 mm
- Stratos PARA Z/1-12; 180 mm

For avoiding condensation formation on the surface of the pump housing and consequential damage caused by drips and corrosion on the pump housing and on the rest of the system.

> Application benefits and field of application

- Industrially prefabricated low-temperature insulation shell for the fast insulation of pump housings and secure connection with onsite diffusion-proof pipe insulation.
- Permitted temperature range of the fluid: $-10\text{ }^{\circ}\text{C}$ to $+85\text{ }^{\circ}\text{C}$
- Simple contours and surfaces facilitate the application of any onsite surface coatings (e.g. coat of paint for UV protection, sheet metal application for impact protection)
- Dimensionally precise adjustment to the housing geometry reduces the hollow space between insulation and the pump housing and thus the inclusion of air and moisture
- The flexible elastomer insulation material can be cut and re-glued in situations where access for installation is difficult